



Height Adjustable Smart Stand

Raise Your Monitor to Eye Level
Increase Viewing Comfort

Multi-purpose Application

accommodates most 13"-32" monitors,
laptop, printers and other office machine



AMS-1/AMS-1L



Shelf & Drawer Design

maximizes storage space
under platform.



Front Slot

holds most tablets and
phones.



Side Groove

stores small-size office supplies,
such as pens, rubber, etc.



Built-in Cable Manager

routes cables neatly.



Stacking Columns Design

provides height adjustment
customization and easy
installation in seconds.



AMS-2/AMS-2L
with Drawer



Non-skid EVA Foam Feet

protects work surface from
scratches or scuffs.



AMS-3/AMS-3L
with Two-Shelves and Drawer

Height Adjustable Smart Stand

Brateck[®]
BRACKET TECHNOLOGY

Rated **10kg/22lbs**
Each layer

Cable Management

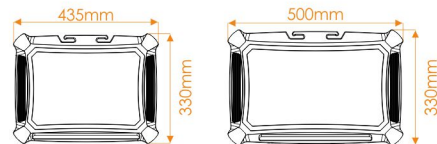

Standard Platform

Large Platform

AMS-1

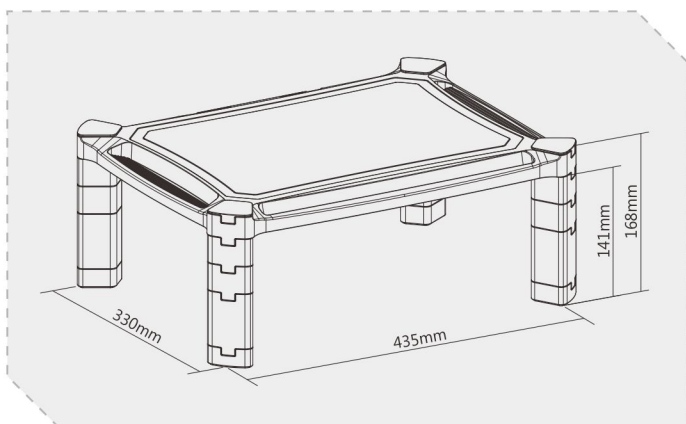

AMS-1L

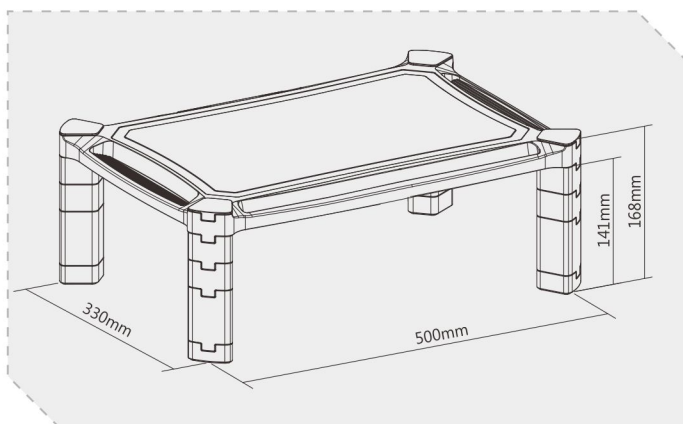

AMS-2

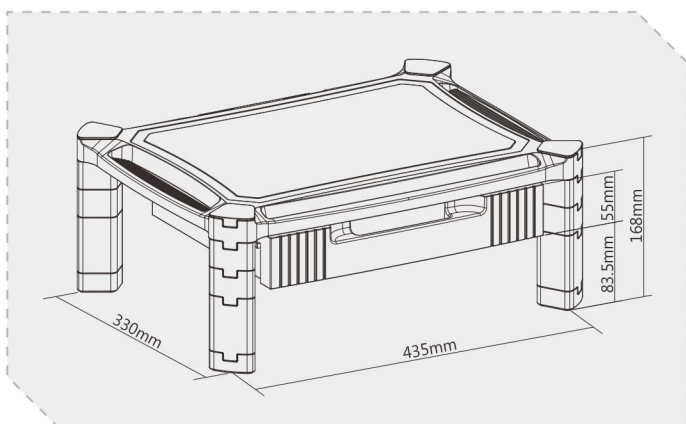

AMS-2L

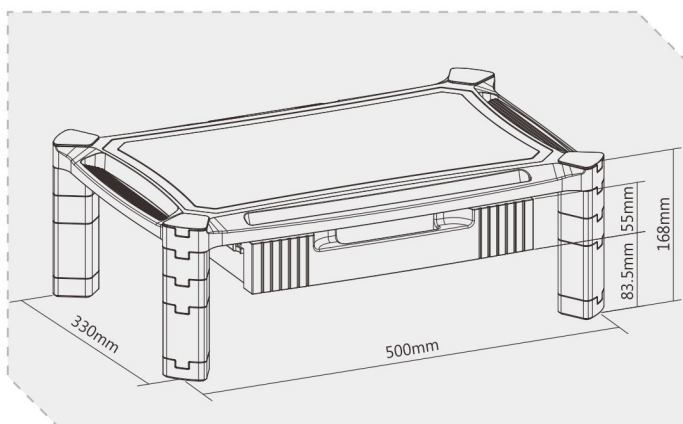

AMS-3

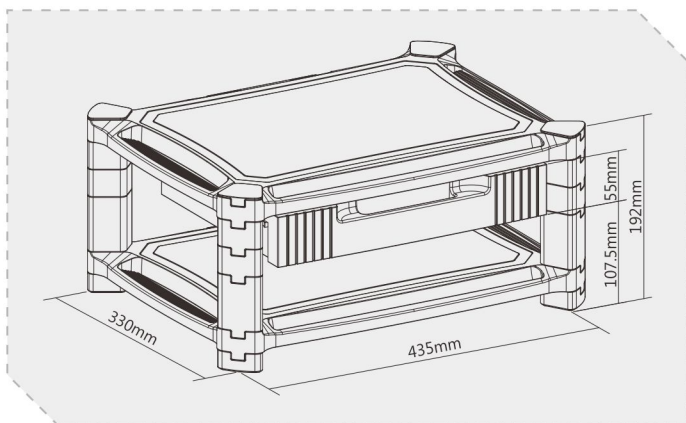

AMS-3L

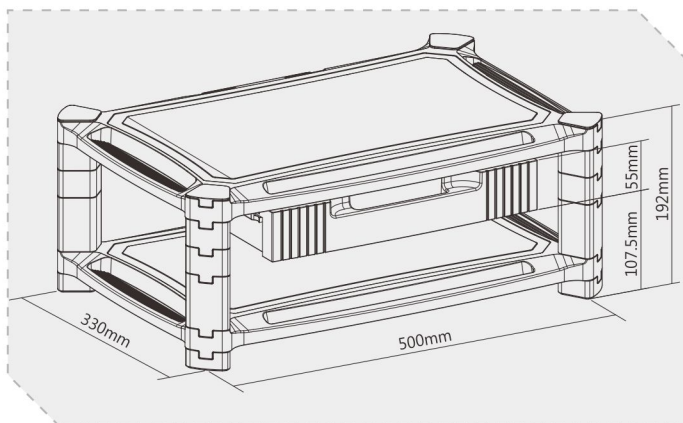

Height Adjustable Smart Cart

Your Desk Side Assistant
Accommodate Most Laser or Inkjet Printers



AMS-5/AMS-5L
with 3-Shelves and Drawer

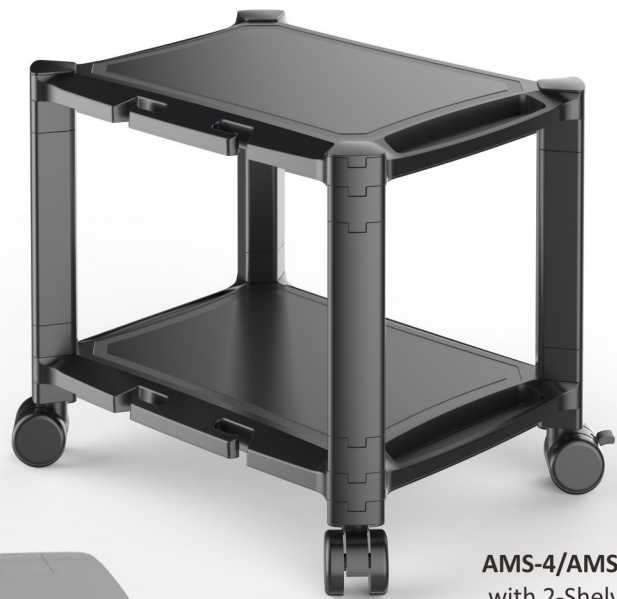

AMS-4/AMS-4L
with 2-Shelves



Easy Assembly,
No Tools Required.



Four Casters with Two Locking
for mobility.

Height Adjustable Smart Cart

Brateck[®]
BRACKET TECHNOLOGY

Rated **10kg/22lbs**
Each layer

Cable Management

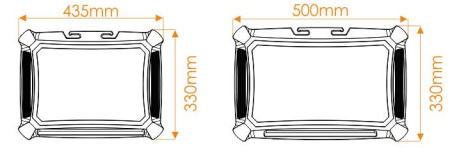

Standard Platform

Large Platform

AMS-4

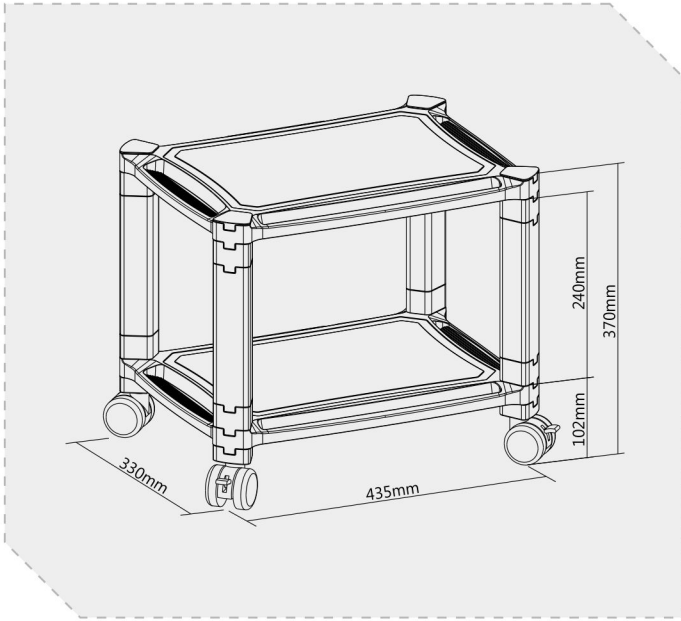

AMS-4L

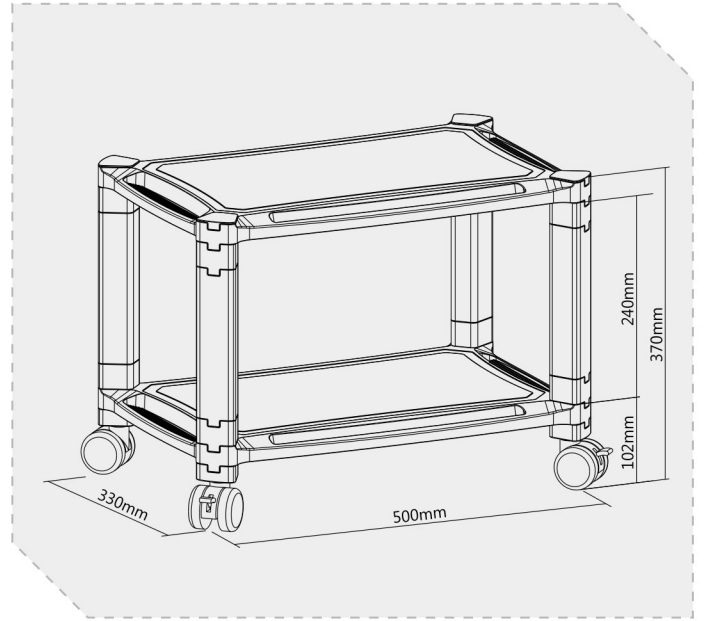

AMS-5

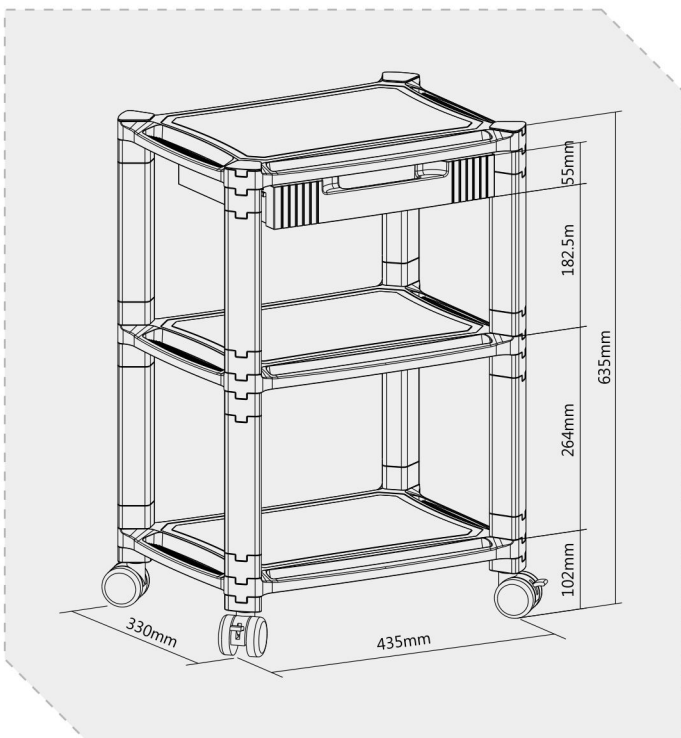

AMS-5L

